

6TJL

Frameless Swing Door with Double In-Line Panels



LASCO[®]
BATHWARE

For Technical Assistance, call **1-877-723-7190** (toll free)

Other Questions, call **1-800-877-2005**

PARTS LIST

FRAME PACKAGE

KEY	DESCRIPTION	PART	QTY
A	SILL (with weep holes)	A782	1
B	HEADER	A781	1
C	HEADER/SILL INSERT	A716	2
D	JAMB	A083 / A883	4
E	MAGNETIC DOOR STOP	A989	1
F	VINYL DRIP SWEEP	V001	1
G	VINYL DOOR SEAL	V678	2
H	VERTICAL GLAZING	VK250V	
I	HORIZONTAL GLAZING	VK250H	

HARDWARE BAG

J	HINGE	H006	2
K	PUSH/PULL HANDLE KIT	HTG6	1
	PLASTIC WASHER		4
	EXTERIOR PULL HANDLE		1
	INTERIOR PULL HANDLE		1
	BUSHING		2
	HANDLE CONNECTOR SCREW		2
R	MAGNETIC CATCHKIT	HKMAGCH	1
	MAGNET HOLDER WITH MAGNET		1
	METAL SLIDE		1
	HANDLE VINYL		1
L	8A X 1 1/4" PAN HEAD SCREW	H480	8
M	8A X 3/8" PAN HD SCR SELF DRILL	H901	16
N	ANCHOR	H002	8
O	PLASTIC SETTING BLOCK	HK01	4
P	3/32 ALLEN WRENCH	H635	1
Q	4MM ALLEN WRENCH	H636	1

TOOLS NEEDED

1/8" Drill Bit
 3/16" Drill Bit
 (3/16" Masonry Bit for Ceramic Tile)

Pencil
 Measuring Tape
 Hacksaw
 Phillips Screw Driver
 Silicone Caulk
 File
 Drill
 Level
 Masking Tape

Before starting installation of your shower enclosure, carefully read all instructions and lay out parts to become familiar with their identity.

Frameless patch-hinge doors, by nature of their design, are not completely watertight.

CAUTION

Do not attempt to cut mirrors or glass used in this enclosure. Tempered glass and mirror will shatter if cut.

Care should be taken when standing raw glass on its edge. Glass may shatter if corners are bumped or edge is rested on a rough floor surface. Cardboard, wood blocks (provided with hardware), or a similar surface is a safe resting surface for glass.

CLEANING

Cleaning and care of your enclosure is important to its lasting beauty. We suggest using a nonabrasive liquid cleaner.
Never use scouring powder or pads.

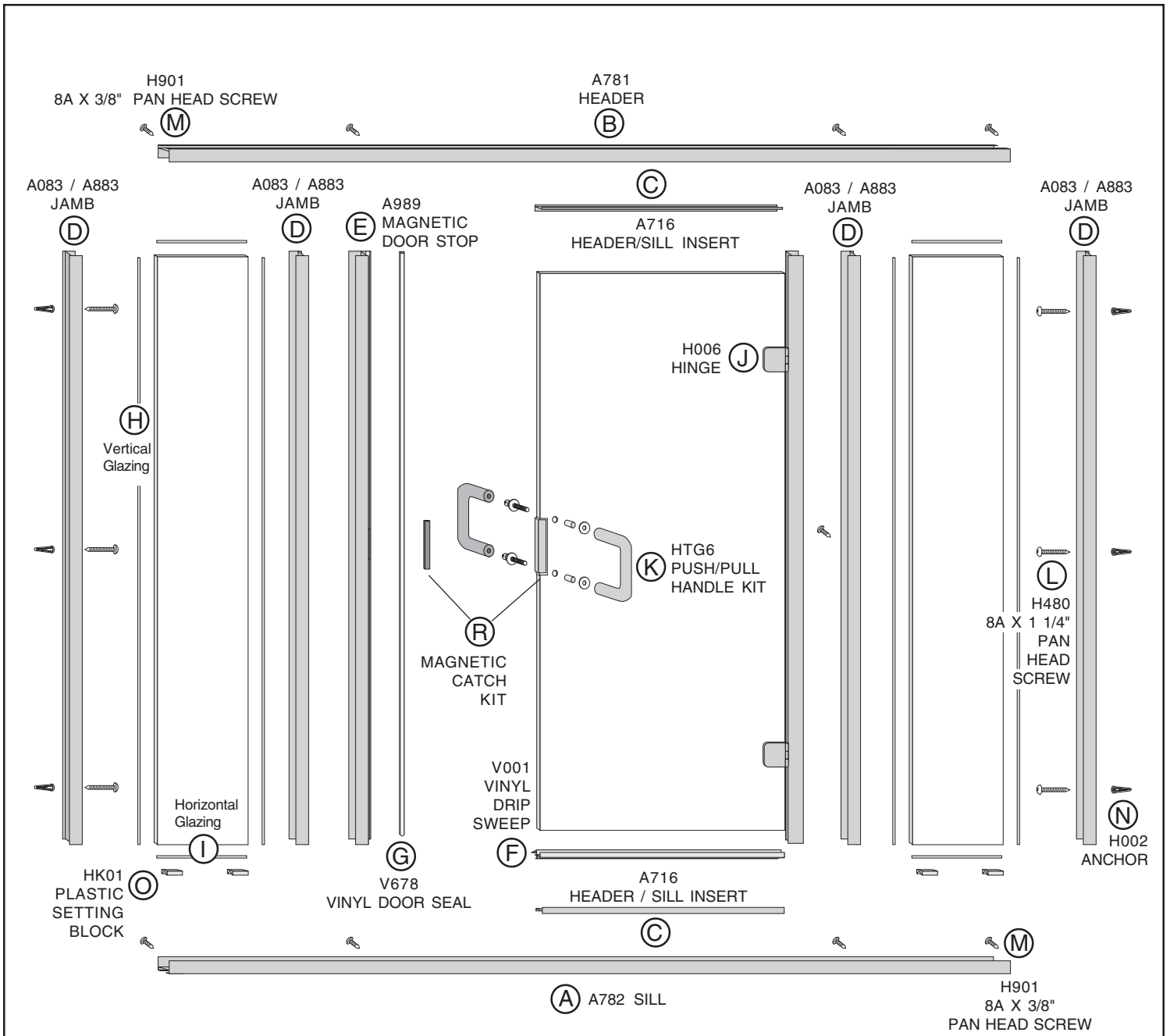

OUTSIDE OF SHOWER



(L) 8A x 1 1/4 Pan Head Screw
(H480 - Used for Jamb)

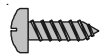

(M) 8A x 3/8 Pan Head Self Drilling Screw
(H901 - Used for Securing Verticals)

1

Sill (A)

Header and sill are identical except that the sill has weep holes on inside surface. Identify sill with weep holes.

Determine placement of **sill (A)** on shower threshold. Normally door is installed with sill centered on the flat surface of threshold.

Measure opening at threshold and cut sill to that measurement. If necessary, file sharp edges to fit rounded corners of your unit.

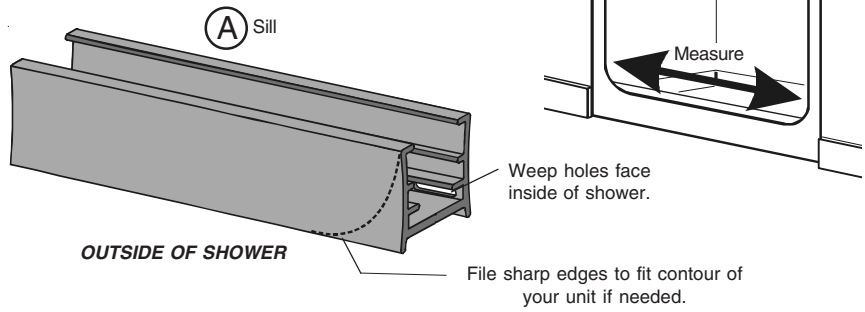

2

Sill (A)

With sill in upside down position, apply a 1/4" bead of caulk along bottom of sill.

Position sill on threshold with weep holes facing inside of shower. Tape to threshold with masking tape to hold in place while positioning jambs.

Clean caulk that squeezes out from under sill with a wooden wedge, plastic scraper, or popsicle stick.

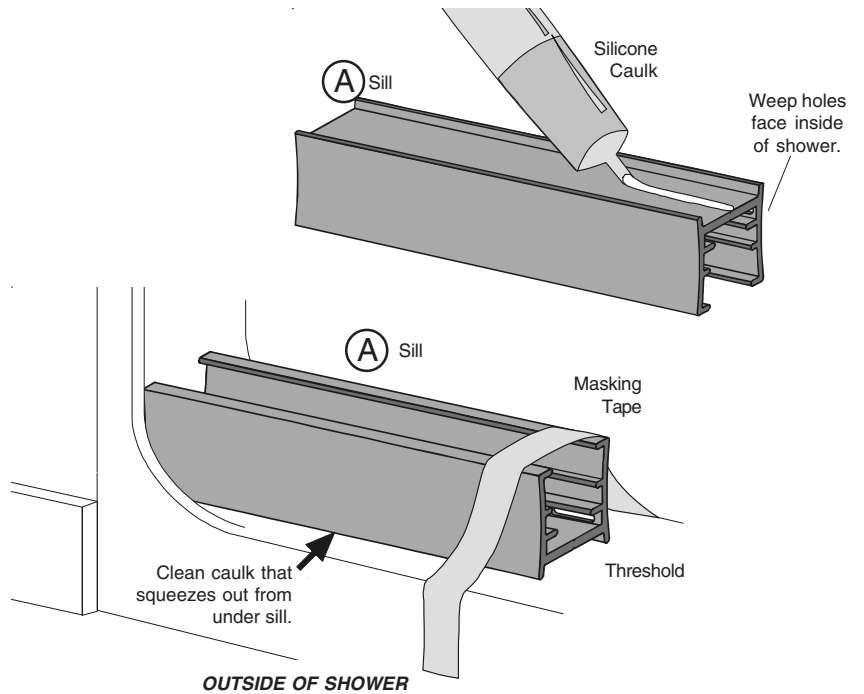

3

Jambs (D)

When anchors (N) are used holes should be drilled using 3/16" drill bit.

Position **jamb (D)** on sill with short legs against wall and bottom of jamb inside sill. If necessary, file sharp edges on bottom of jamb to fit rounded corners of your unit.

Align jamb vertically using a level. Drill mounting holes through jamb into wall using 1/8" drill bit. Mounting holes are normally located 3" from top and bottom of jamb and at center.

Secure jamb to wall using **8A x 1 1/4" pan head screws (L)**.

Repeat for opposite side.

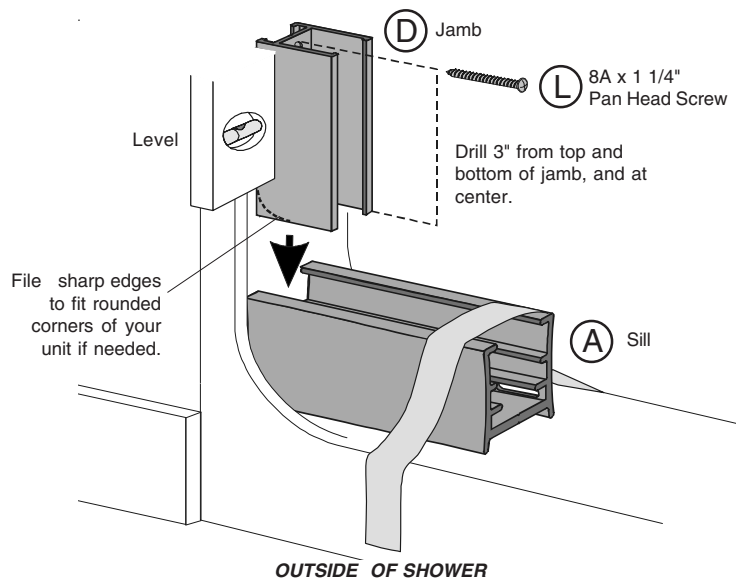

4 Setting Blocks (O) / Side Panels

The following instructions call for glass to seat in verticals 3/8". This distance may be adjusted from 1/4" - 1/2" to accommodate out-of-plumb walls and allow for a better fit of parts.

Plastic **setting blocks (O)** are used in sill to provide a resting surface for panel glass. Place one setting block in sill at edge of wall jamb. A second setting block should be placed in sill to support remaining corner of panel glass once glass is placed in unit. Measure panel glass and position remaining setting block accordingly.

Place panel glass in wall jamb with bottom of glass resting on setting blocks in sill and side of glass seated in wall jamb 3/8". Repeat for opposite panel.

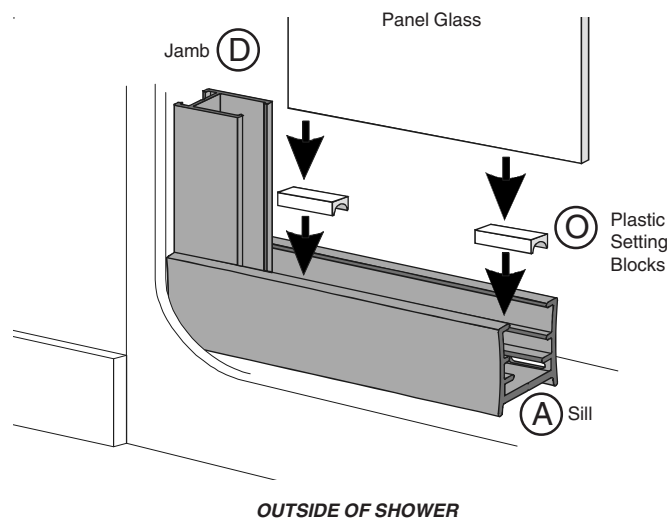

5 Jambs (D) / Magnetic Door Stop (E)

Place remaining **jambs** (panel jambs) over panel glass with long leg of jambs fitting over edge of glass 3/8", and bottom of jambs seated in sill.

Decide which will be the opening side of your door. Door is normally installed to open on the side of unit nearest to showerhead.

On opening side of unit, slide **magnetic door stop (E)** over panel jamb, with bottom of door stop seated in sill and **vinyl door seal (G)** facing outside of shower.

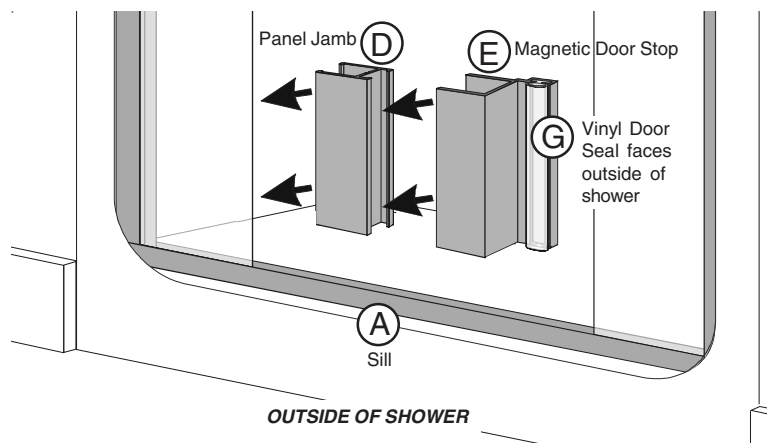
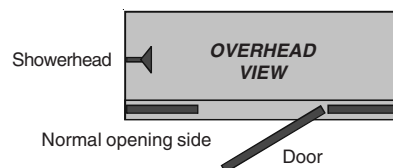

6 Hinge Door Stop

On opposite side of unit, place **hinge door stop** (with door attached) over panel jamb with bottom of door stop seated in sill. For safety purposes, door should be installed to open out from shower.

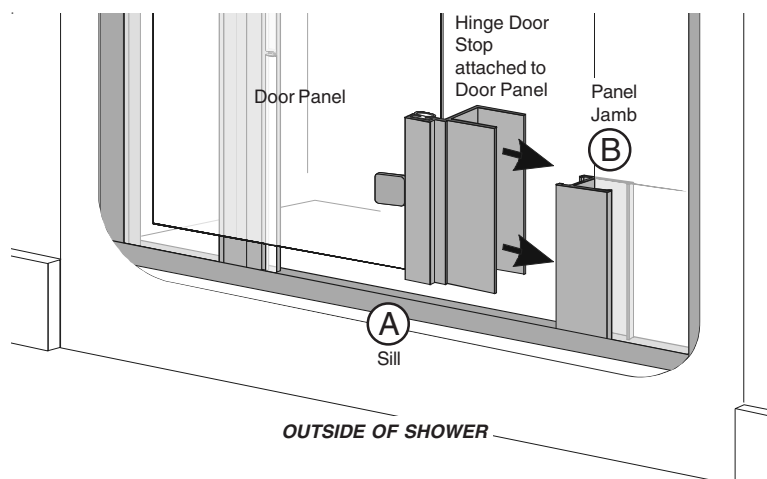

7

Magnetic Catch Kit (R)

Vinyl door seal (G) will be removed from channel of magnetic door stop, trimmed into two pieces, and replaced in channel with metal slide (attached to magnet in magnetic catch kit) in between.

Mark center of magnetic door stop. Trim vinyl door seal to fill open channel of door stop from sill to 2" below center mark.

Insert vinyl in channel.

Insert metal slide in channel on top of vinyl.

Insert remaining piece of vinyl in channel on top of metal slide. Trim vinyl flush with top of magnetic door stop using a sharp knife.

Wrap handle vinyl, from magnetic catch kit (R), around edge of door glass adjacent to the metal slide in door stop.

Tap magnet holder, with magnet attached, over vinyl. Magnet should face inside of shower.

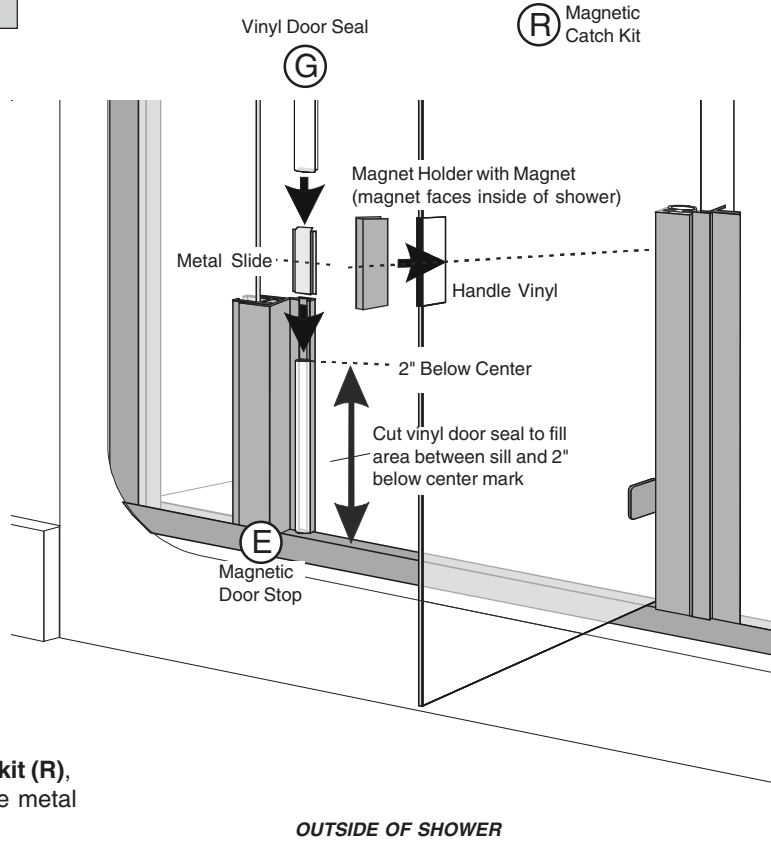

8

Header (B)

Measure from wall to wall (over the top of jambs) and cut header (B) to that measurement.

Lower header into place over jambs.

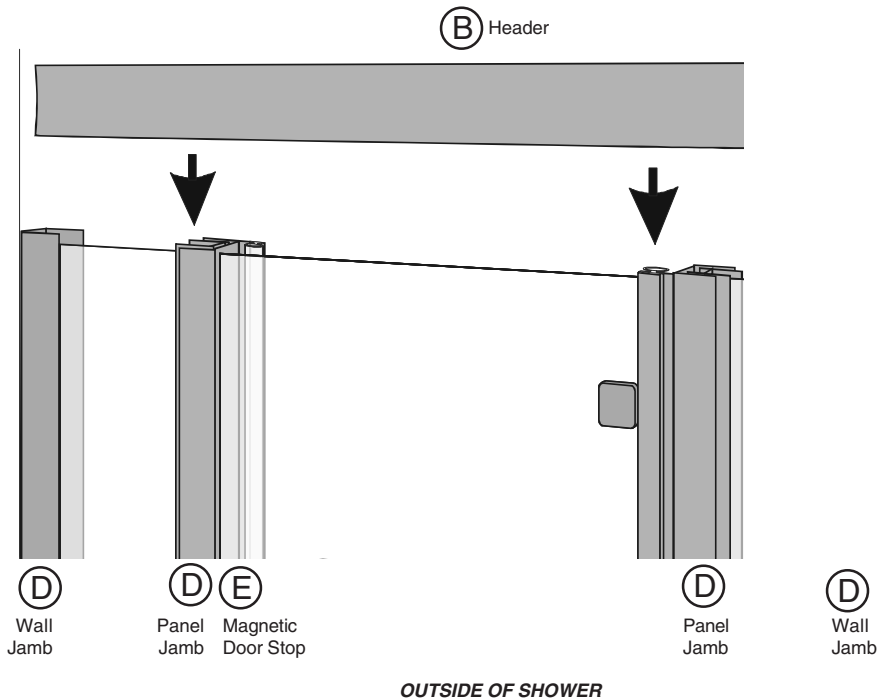

9

Sill / Header Inserts (C)

At bottom of door, snap **sill / header insert (C)** into sill with tall edge of insert toward outside of shower.

At top of door, snap **sill / header insert (C)** into header with tall edge of insert toward inside of shower.

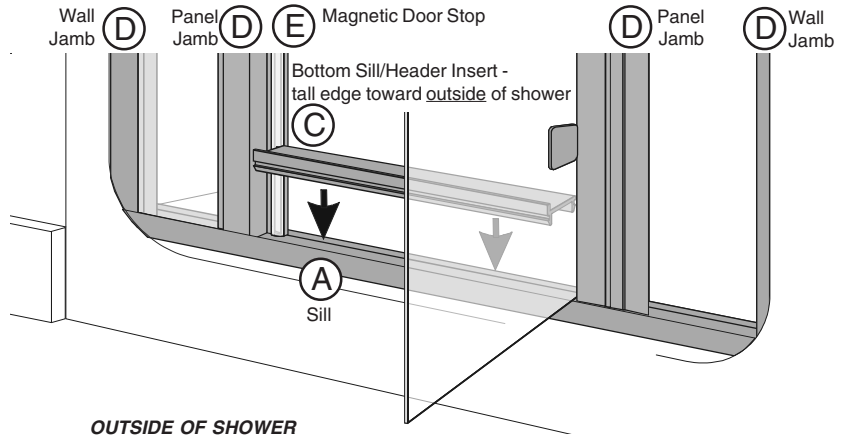

OUTSIDE OF SHOWER

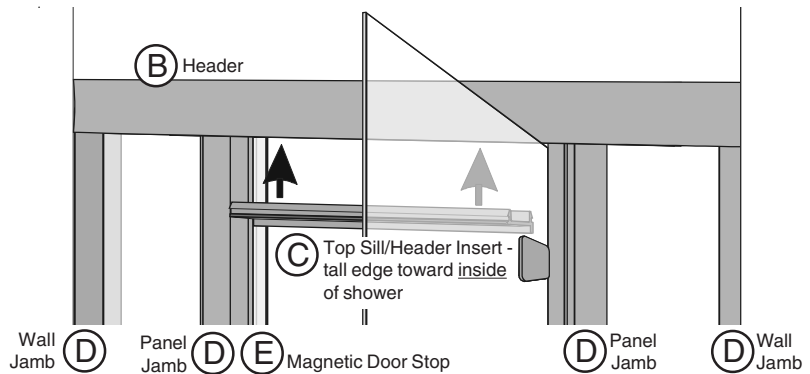

10

Aligning / Securing Verticals

When drilling or screwing into metal, make certain that glass is clear from area.

Check alignment of door, panel glass, panel jambs, and magnetic door stop. Adjust as needed so that door closes evenly, there is an even reveal of space at top and bottom of door glass, and magnetic slide aligns with handle magnet.

Once desired alignment of parts has been achieved, secure parts together from inside of shower using **8A x 3/8" self tapping screws (M)**.

- At top of unit, attach wall jambs to header. At bottom of unit, attach wall jambs to sill.
- Attach panel jamb to hinge door stop in three locations - at top of unit, securing header, jamb and door stop together; at midpoint; and at bottom of unit, securing sill, jamb and door stop together.
- Attach magnetic door stop to panel jamb in two locations - at top, securing header, magnetic door stop and panel jamb together, and at bottom, securing sill, magnetic door stop and panel jamb together.

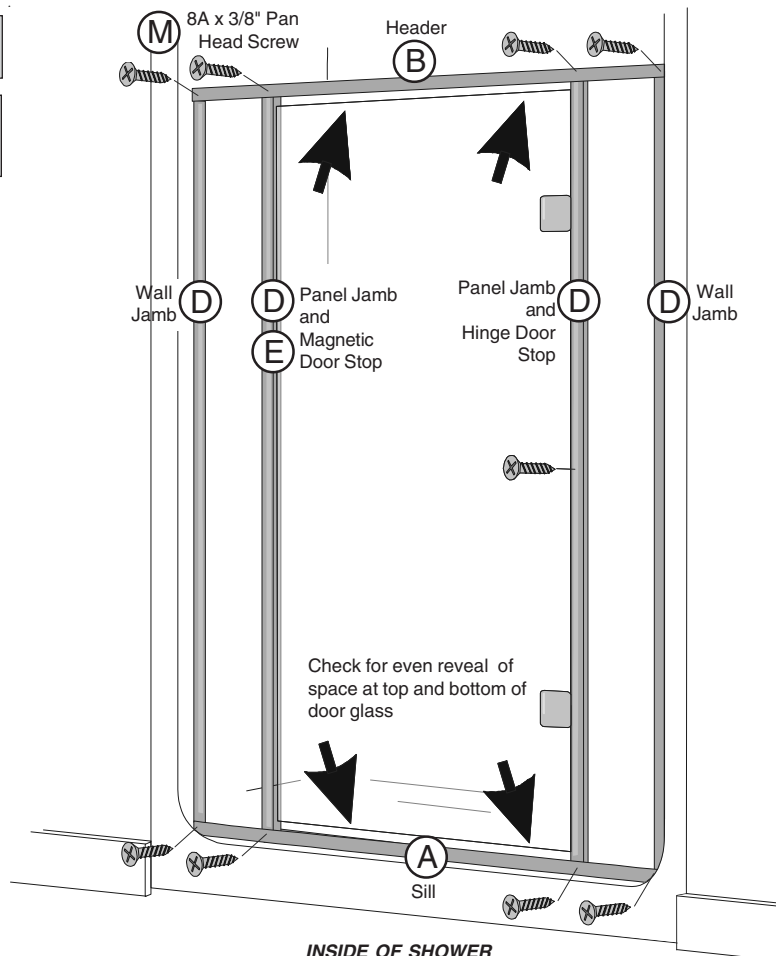

INSIDE OF SHOWER

11

Handle (K)

Push/Pull handle kit (K) comes with parts assembled in the order they will be once installed on glass. Using **3/32 allen wrench**, loosen **set screws** on interior handle and slip handle off **handle connector screws**. Remove connector screws from exterior handle. Remove **plastic washers** and **bushings** from connector screws.

Place **bushings** in holes in glass. Trim as needed so that bushings are flush with surface of glass. Place one **plastic washer** on each **connector screw**. From inside shower, insert connector screws through holes in glass. Place second **plastic washer** on end of each connector screw on outside of glass. Hold **exterior handle** in place on outside of glass and secure by tightening connector screws. On inside of shower, slip **interior handle** over connector screws and tighten in place with allen wrench.

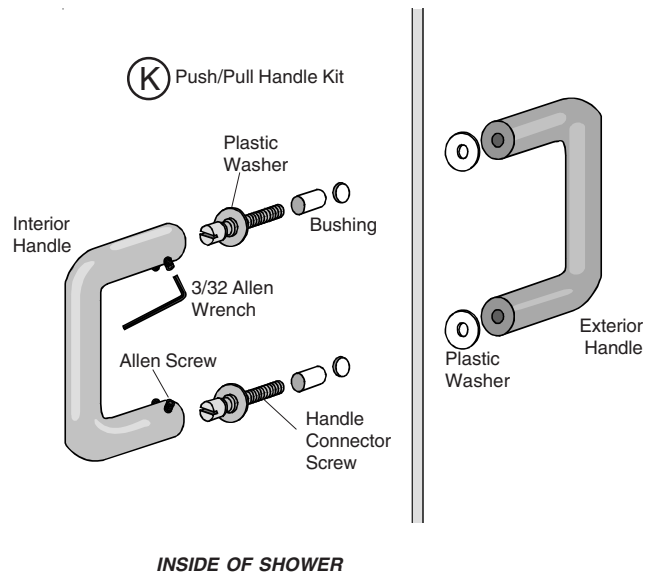

12

Vertical Glazing (H)

Vinyl glazing is used to cushion and secure glass in metal. There are two types of vinyl glazing included in your unit - **horizontal (I)** and **vertical (H)**. The vertical glazing is thinner and will be installed first.

Water may be used to lubricate glazing and make installation easier. Glazing is designed to fit tightly. A wooden block may be used to press vinyl into place.

Measure length of panel glass from header to sill and add 1/4". Cut 2 pieces of **vertical glazing (H)** to this measurement, one for inside and one for outside of panel.

Press ends of glazing into place first, fitting glazing into gap between metal and glass. Work toward center, pressing glazing into place.

Repeat for inside of shower and for opposite side of panel on inside and outside of shower.

Repeat for glazing panel on hinge side of door.

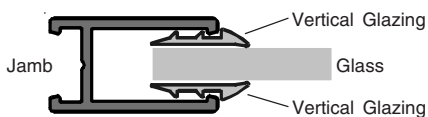
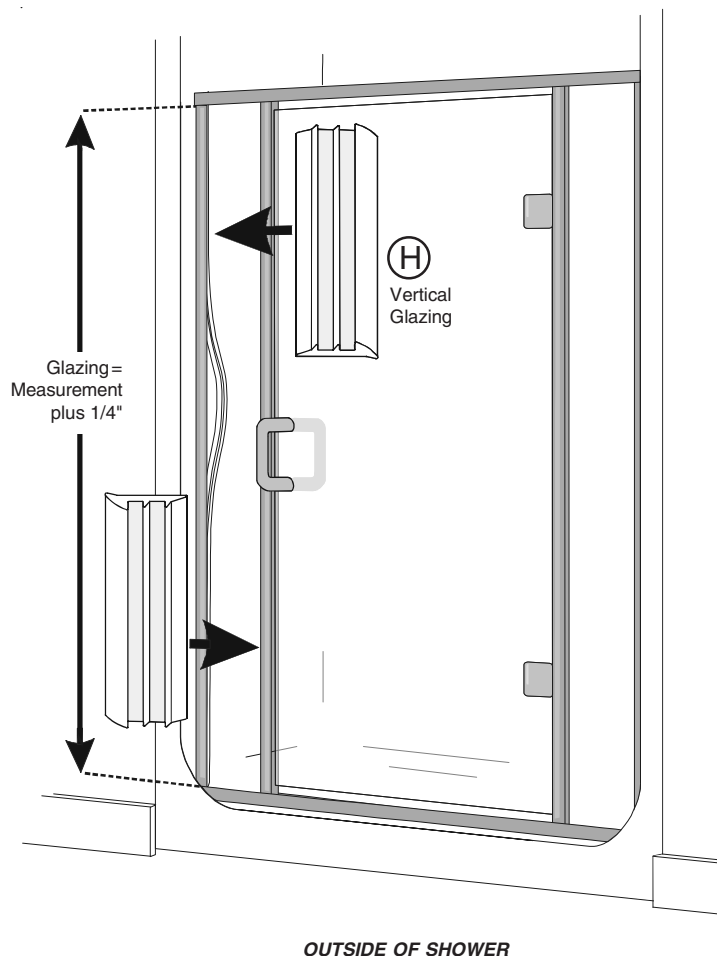

13

Horizontal Glazing (I)

Apply **horizontal glazing (I)** on inside and outside of panel between glass and header at top of unit, and between glass and sill at bottom of unit.

For a smoother fit in corners where horizontal and vertical glazings meet, the ends of horizontal glazing may be trimmed at a 45° angle. Trim only the exterior ridge of glazing, not the section of glazing that fits inside metal once installed.

Repeat for glazing top and bottom of panel on hinge side of door.

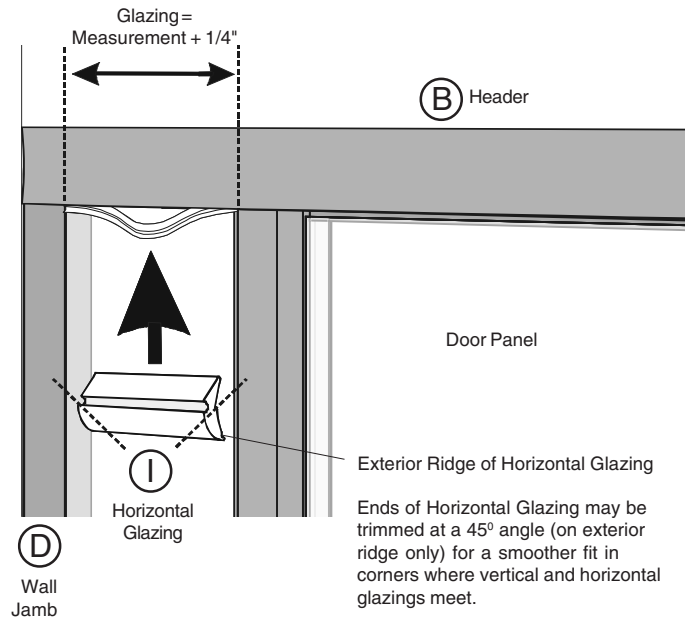
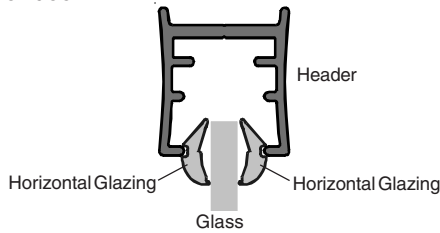

OUTSIDE OF SHOWER

14

Vinyl Drip Sweep (F)

Measure width of door glass at bottom.

Trim **vinyl drip sweep (F)** to door glass width minus 1/8". Trim only from door hinging end of drip sweep. Contour cut end of drip sweep fin to remove sharp point.

Press drip sweep onto bottom edge of door glass with fin facing inside of shower and edge of drip sweep flush with edge of glass on hinging side of door.

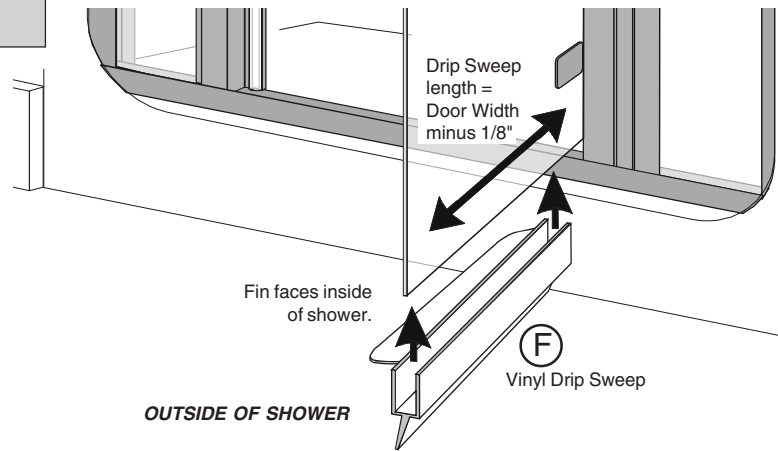

OUTSIDE OF SHOWER

15

Caulking

Seal unit by caulking along outside of enclosure where metal and bath meet, especially where sill meets threshold.

If desired, caulk inside of enclosure where jambs meet walls.

