

2FG1L

Frameless Bypass Enclosure



LASCO[®]
BATHWARE

For Technical Assistance, call **1-877-723-7190** (toll free)

Other Questions, call **1-800-877-2005**

PARTS LIST

FRAME PACKAGE

KEY	DESCRIPTION	PART	QTY
A	SILL	A925	1
B	JAMB	A901	2
C	HEADER	A920	1
V	VINYL TRACK GUIDE	V436	1

HARDWARE BAG

D	TOWEL BAR KIT	HT24	
	TOWEL BAR	HT24	2
	ROUNDBUSHING		4
	PLASTIC WASHER		8
	HANDLE / END CAP		4
E	ROLLER	H342	4
K	8-32 X 3/8 TRUSS HEAD SCREW	H430	4
G	GUIDE	HA20	1
L	8A X 3/8 PAN HEAD SELF DRILLING SCREW	H901	1
H	BUMPER	HB01	4
I	8A X 1 1/4 PAN HEAD SCREW	H480	6
J	ANCHOR	H002	6
M	TOP CHANNEL/ROLLER FIN (II)	A802	2
N	PLASTIC POST (II)	H906	4
O	10-32 X 3/8 PAN HEAD SCREW (II)	H905	4

(II) May be pre-installed on some units and not included in hardware bag.

TOOLS NEEDED

1/8" Drill Bit
 3/16" Drill Bit
 (3/16" Masonry Bit for Ceramic Tile)
 1/4" Drill Bit
 Pencil
 Measuring Tape
 Hacksaw
 Phillips Screw Driver
 Silicone Caulk
 File
 Drill
 Level
 Masking Tape

Before starting installation of your new enclosure, carefully read all instructions and lay out parts to become familiar with their identity.

USE OF ANCHORS

Anchors are furnished with every enclosure. However, the use of anchors is not recommended when attaching your enclosure to a fiberglass unit or wall surrounds with board reinforced mounting areas. Mounting holes in this case should be drilled with an 1/8" drill bit.

Mounting of this unit on tile requires the use of anchors. Special care must be taken not to crack the tile. Before drilling holes in the tile, lightly chip glazed surface of tile at the desired locations. Drill holes using a 3/16" masonry drill bit. Insert anchors into the holes making certain that ring on large end of anchor meets the surface of the tile.

CLEANING

Cleaning and care of your enclosure is important to its lasting beauty. We suggest using a nonabrasive liquid cleaner.
Never use scouring powder or pads.

SEALING

The use of a caulking compound can assure a water-tight seal when applied along outside edge of the enclosure where metal and bath meet. If desired, caulk inside of enclosure where jambs meet walls.

**Do not try to cut the mirrors or glass used in this enclosure.
 Tempered glass and mirrors will disintegrate if cut.**

A920
HEADER (C)



(K) H430
TRUSS HEAD SCREW

(M) A802
TOP CHANNEL/
ROLLER FIN

(E) H342
ROLLER

(D) HT24
TOWEL BAR KIT

PLASTIC
WASHER

ROUND
BUSHING

END
CAP

TOWEL BAR

H480
PAN
HEAD
SCREW

(I)

H002
ANCHOR

(J)

HB01
BUMPER

(H)

A901
JAMB (B)

H901
PAN HEAD SELF
DRILLING SCREW (L)

(G) HA20
GUIDE

(V) V436
VINYL TRACK GUIDE

A925
SILL (A)

OUTSIDE OF SHOWER



(I) **8A x 1 1/4 Pan Head Screw**
(H480 - Used for Jamb)



(L) **8A x 3/8 Pan Head Self Drilling Screw**
(H901 - Used for securing Guide)

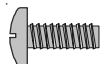

(C) **10-32 x 3/8 Pan Head Screw**
(H905 - Used for Roller Fin)

May be pre-installed on some units and not included in hardware bag.



(K) **8-32 x 3/8 Truss Head Screw**
(H430 - Used for Rollers)

1

Sill (A) / Guides (V, G)

Due to the manufacturing process, there may be rack marks present at one end of your sill and header. Sill and header must be trimmed to fit your individual opening. When cutting sill and header, make certain to trim off end with rack marks.

Measure wall to wall at tub level, and cut your **sill (A)** to that measurement.

Slide **vinyl track guide (V)** into small groove on upright of sill. Trim end flush with edge of sill.

Locate center of sill. Position **guide (G)** at center of sill with curved leg fitting over curve of sill, and back of guide fitting under small lip on back upright of sill.

Drill through hole in guide using 1/8" drill bit. (*Chrome and gold units include a self-drilling screw which does not require a pilot hole.*)

Secure guide to sill with **8A x 3/8" pan head screw (L)**.

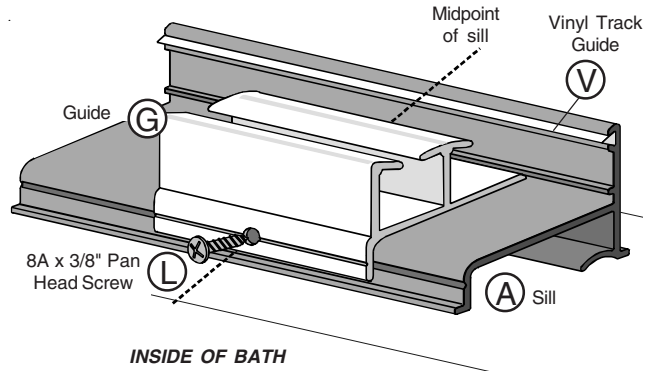
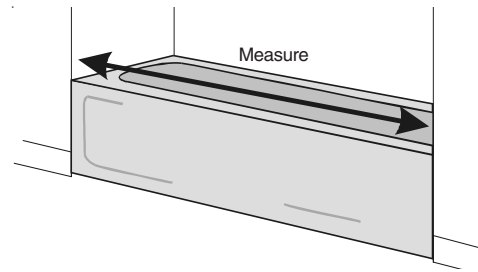

2

Jambs (B)

When anchors (J) are used holes should be drilled using 3/16" drill bit. (Use masonry bit for tile.)

Position sill on centerline of tub with tall edge of sill toward outside of tub. Tape sill to tub with masking tape. This will help hold sill in place while positioning jambs.

Place one **jamb (B)** against wall with short legs against wall and notched end of jamb resting on sill. If necessary for a smooth fit, file back of jamb (short legs) to fit contour of your unit. Align jamb vertically using a level and mark wall through prepunched holes. Repeat with remaining jamb.

Remove jambs from tub and drill where marked using 1/8" drill bit.

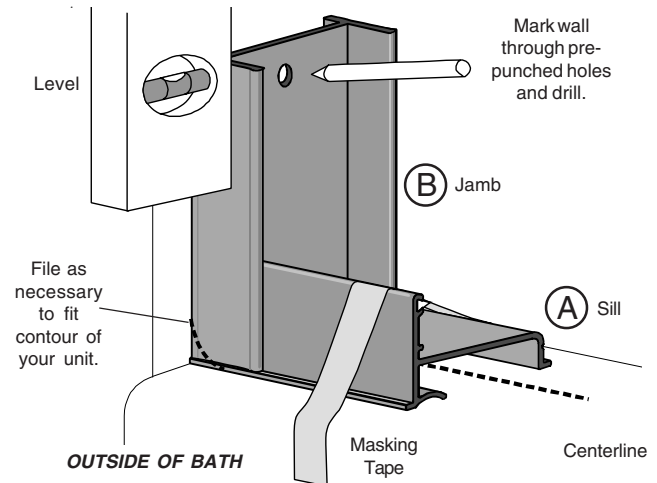

3

Bumpers (H)

Reposition jambs on tub and mount to wall using **8A x 1 1/4" pan head screws (I)**. Top and bottom holes are mounting positions for **bumpers (H)**.

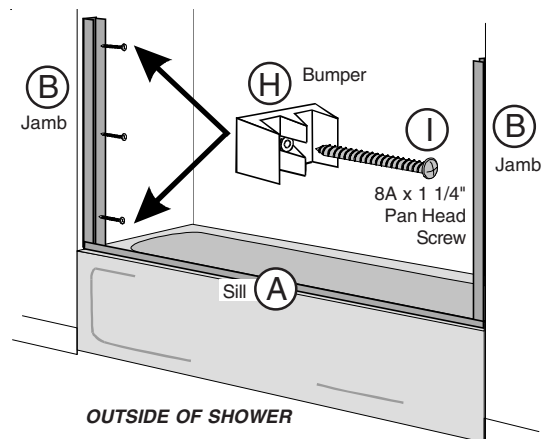

4

Header (C)

Measure from wall to wall (over the top of both jambs) and cut **header (C)** to that measurement.

Lower header over jambs until seated squarely on legs of both jambs.

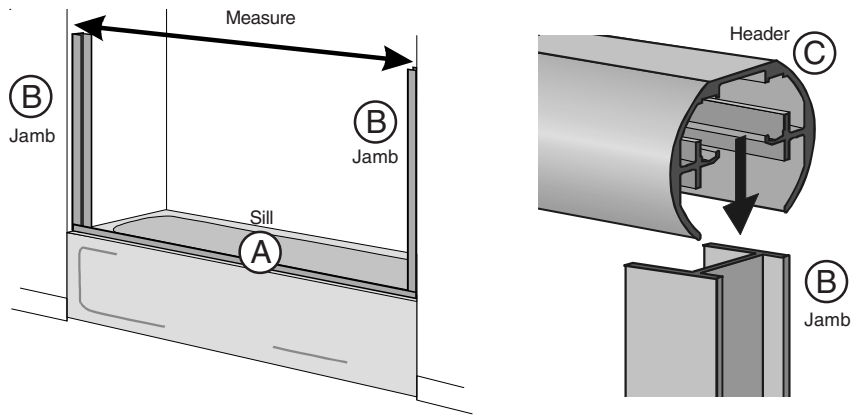

5

Roller Fin (M)

Some units come with top channel/roller fin pre-installed on door panels. If pre-installed on your unit, proceed to Step 6.

To mount **top channel/roller fin (M)**, align fin with top of glass and mark through holes in glass. Using 1/4" drill bit, drill fin where marked so that holes in roller fin match holes in glass. Secure fin to glass with **plastic post (N)** and **10-32 x 3/8" pan head screw (O)** provided.

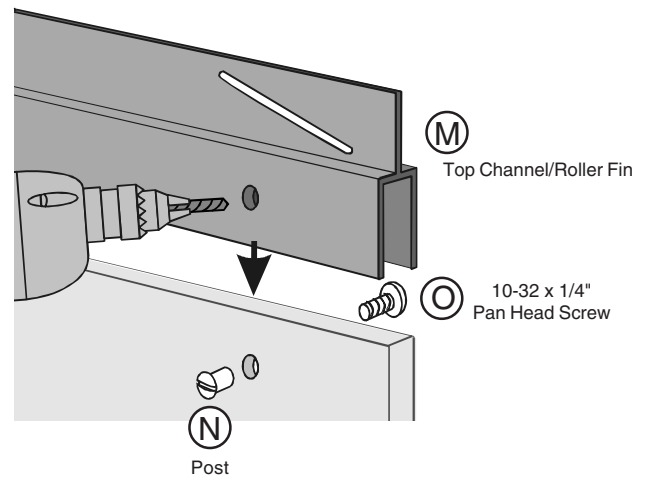

6

Towel Bars (D)

On units with clear, painted glass, the painted surface of glass faces outside of shower.
On units with tinted, painted glass, the painted surface of glass faces inside of shower.

Towel bars are to be mounted onto door panel through predrilled holes in glass. *Towel bar for outside panel faces outside of bath while bar for inside panel faces inside of bath.*

Towel bar kit comes with parts assembled in the order they will be installed on glass. Disassemble parts. Press bushings into holes in glass. Trim as needed so that bushings are flush with surface of the glass.

Reassemble towel bar, plastic washers, and end cap on door panel as shown. Allen wrench may be used to aid in tightening by inserting into hole of end cap and turning. Repeat for remaining door panel.

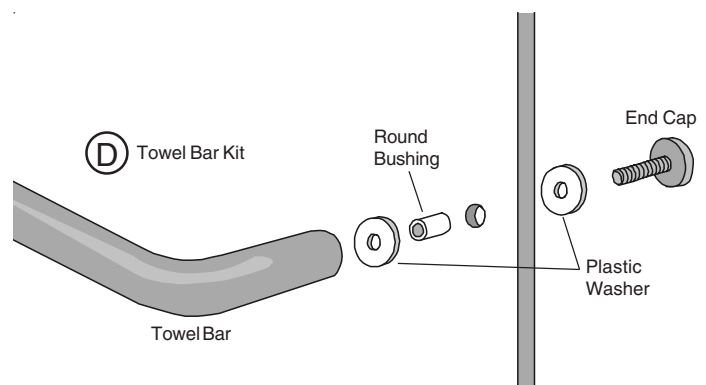
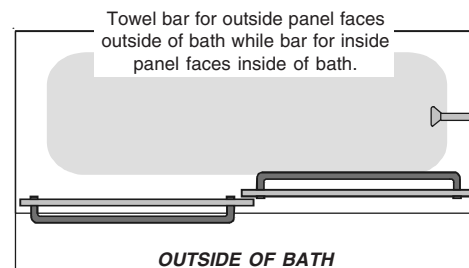

7

Rollers (E)

Mount **rollers (E)** to roller fins using **8-32 x 3/8" truss head screws (K)**. Rollers are to be mounted on same side of doors as towel bars and at the midpoint of slots.

Rollers may be positioned up or down in slots to adjust for out of plumb situations.

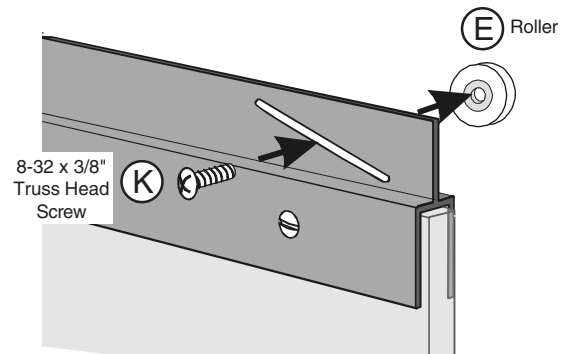

8

Hanging Door Panels

Lift inside door panel into header with towel bar facing inside of bath. Seat rollers on roller track while guiding bottom of door into sill guide.

Repeat for outside door, hanging panel with towel bar facing outside of bath.

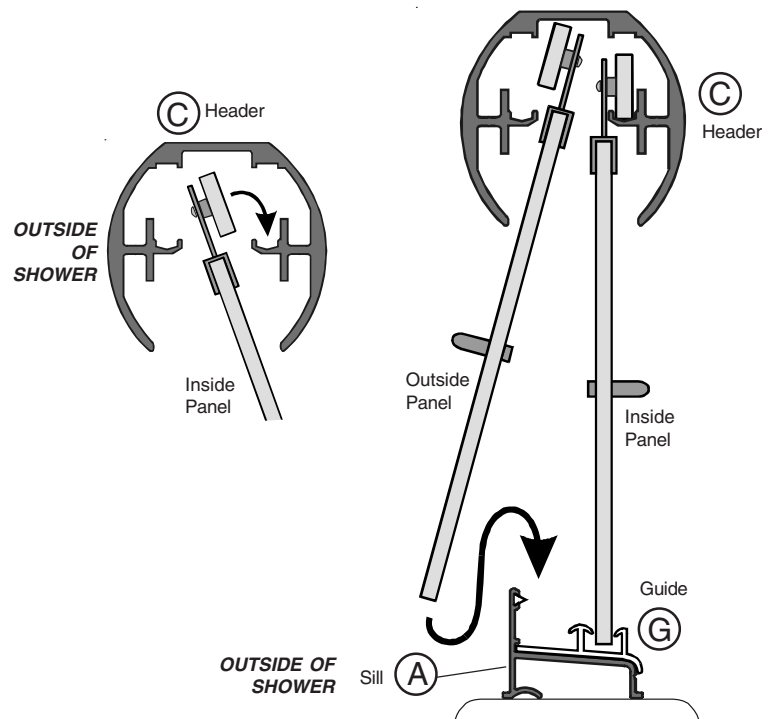

9

Caulking

The use of a caulking compound will assure a water-tight seal. Seal unit by applying caulk along outside edge of enclosure where metal and bath meet, especially where sill meets tub.

If desired, caulk inside of enclosure where jambs meet walls.

